

SMMC-3 MANUAL

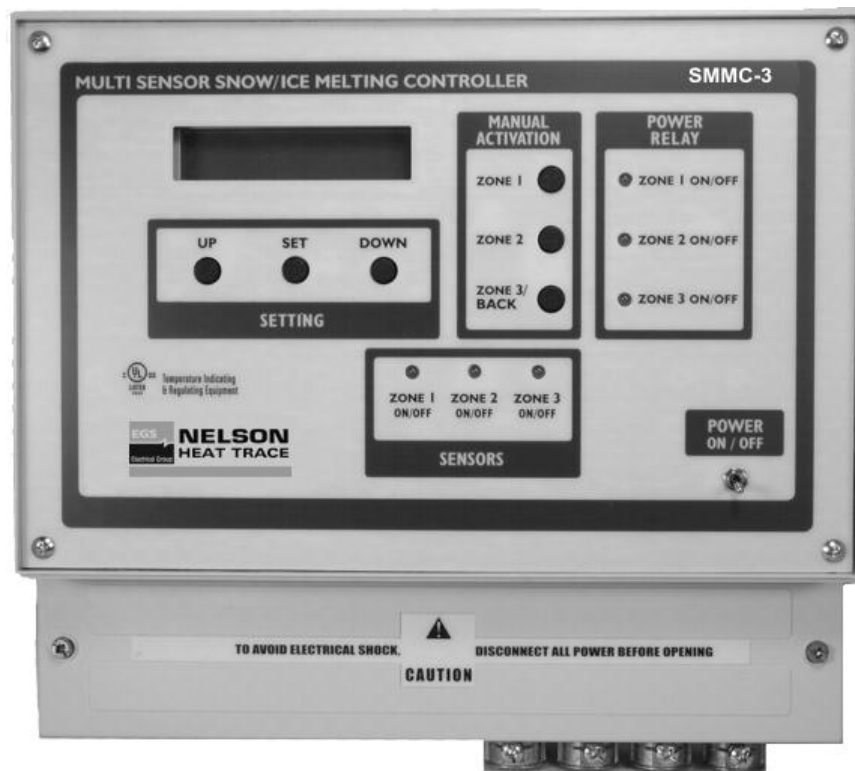

TABLE OF CONTENTS

GENERAL INFORMATION 3

Pre-Programmed Configuration 3

WARNINGS 4

INSTALLATION 4

Pre-Programmed Connections 5

SYSTEM CHECK 6

OPERATION 7

Mode 1 – Independent 7

Mode 2 – Priority 7

Zone Assignment 8

Manual Operation 8

Programming Instructions 9

TROUBLESHOOTING GUIDE 12

SMMC-3 Control panel (access cover removed) 13

SPECIFICATIONS 14

Sensor Extension Wire Specifications 14

LIMITED WARRANTY AND LIABILITY 15

GENERAL INFORMATION

The SMMC-3 Control Panel manages snow and ice melting equipment for sidewalks, driveways, gutters, downspouts, etc. Suitable for controlling all types of heating cable systems, the SMMC-3 can monitor snow and ice accumulation in three separate zones. The SMMC-3 programming allows each zone to be controlled independently or on a priority mode basis. In the priority mode, one zone can be given priority and the other zones cannot be energized until the melting/de-icing in that zone is complete. This can reduce the loading on the system by ensuring that multiple zones are not energized simultaneously. The SMMC-3 program allows customization of the key elements necessary for intelligent and efficient snow melting control.

The SMMC-3 can access information from three different types of moisture sensors . surface (SMPS-1), aerial (SMAS-1) and gutter (SMGS-1) and one temperature sensor (SMTS-1). The surface, aerial and gutter sensors detect moisture from snow, ice, sleet, etc. and send appropriate signals to the SMMC-3. Similarly, the temperature sensor sends temperature data back to the SMMC-3. Independent temperature and moisture information is processed by the SMMC-3 to ensure that heating equipment will only be energized when precipitation occurs during freezing conditions. For each of the SMMC-3 control zones, up to two individual moisture sensors can be connected. However, for each zone only one of these may be a surface sensor. Each SMMC-3 must have a temperature sensor, SMTS-1, in order to function. A SMTS-1 is included with each SMMC-3.

The SMMC-3 is housed in an enclosure suitable for commercial/industrial applications (NEMA 12) and features an LCD display, programming and associated indicator lights for operation of each zone.

The SMMC-3 is powered by 120VAC; control relays provide a 120VAC output to operate external contactors. See Fig. 1 & 2.

PRE-PROGRAMMED CONFIGURATION

The SMMC-3 Control Panel is delivered preprogrammed for a single zone system, for use with either an aerial (SMAS-1) or gutter (SMGS-1) sensor. (Note that the SMMC-3 does not distinguish between the gutter and aerial sensors). The de-energize temperature (the SMMC-3 will not energize the heating equipment when the ambient temperature is warmer than this) is pre-set to 37°F (3°C), and relay hold time (the length of time that the heating equipment will stay energized after it no longer senses the presence of ice/snow in the zone) is 3.0 hours. If the snow/ice melting system has been designed to operate in this manner, then no programming is required: simply wire as per the following instructions.

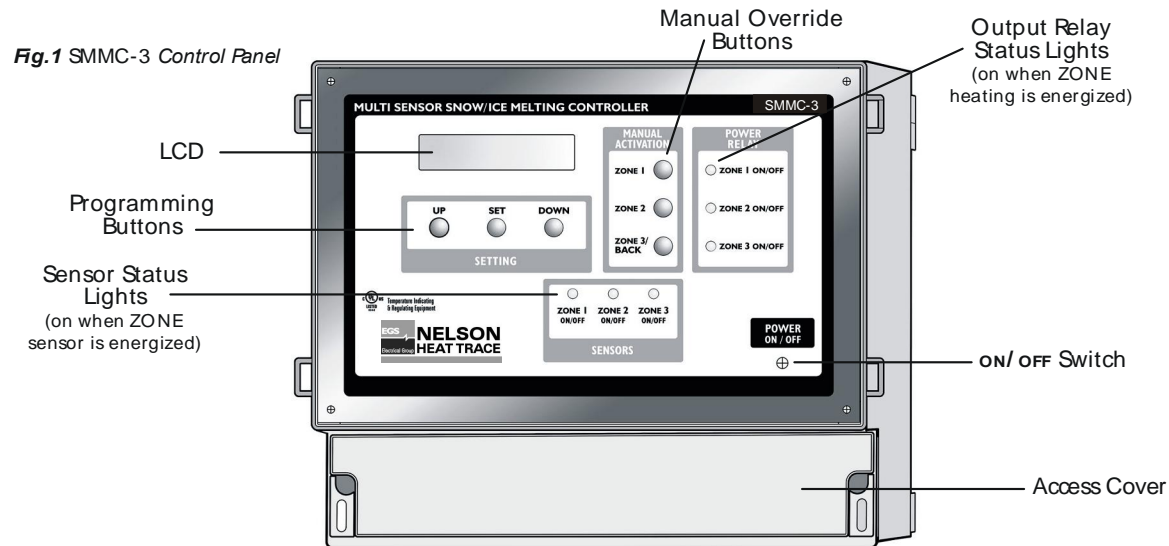
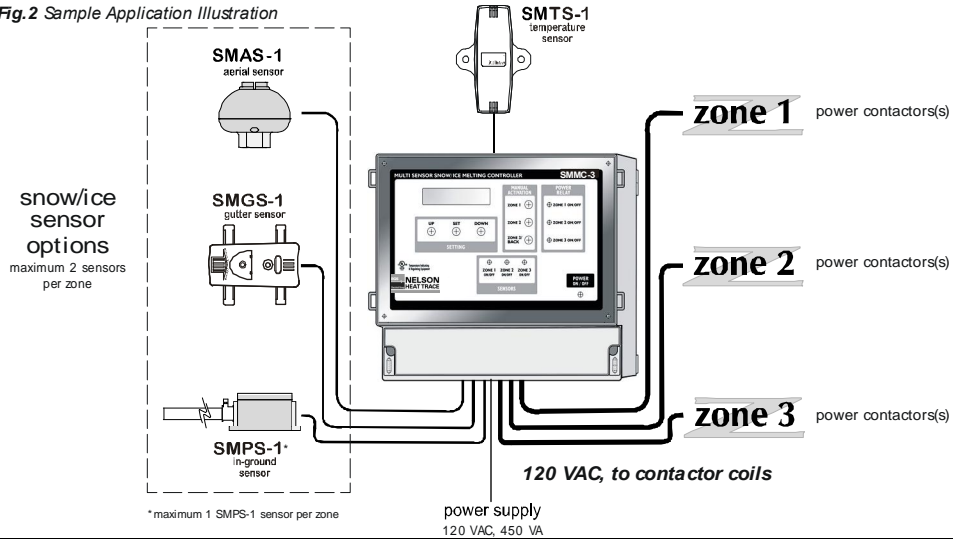

Fig.2 Sample Application Illustration



WARNINGS

1. A qualified electrician must install the SMMC-3.
2. If after carefully reading these instructions you still have questions regarding installation operation or maintenance of this product, call the numbers listed for assistance.
3. Prior to installation, check the SMMC-3 Control Panel for possible shipping damage. Do not install a damaged SMMC-3 Control Panel.
4. All heating equipment, controls & associated systems must be installed in compliance with the latest editions of all applicable electrical codes and ordinances.
5. The SMMC-3 has been designed to accept only Nelson moisture and temperature sensor inputs. The risk of fire or electric shock exists if the SMMC-3 is connected to any device other than a Nelson sensor.
6. Do not connect heating equipment directly to the SMMC-3 Control Panel. The SMMC-3 control relays provide an output to operate external contactors. Each output provides a maximum current output of 1.25A. The risk of fire or electric shock exists if the heating equipment is directly connected to the SMMC-3 Control Panel.
7. These instructions must be saved and made available to owners or users of this product and/or transferred to future owners.
8. Secure the SMMC-3 in an accessible location. The SMMC-3 Control Panel is not suitable for installation environments subject to condensing moisture or those exposed to temperature extremes.
9. Avoid shock or vibration.

INSTALLATION

1. Mount the SMMC-3 securely to the wall with three #10 screws, mount in an upright position in an indoor location, in an area that is dry and not subject to temperature extremes. See Fig. 3 for mounting details.
2. Four 1/2" connectors have been installed on the SMMC-3 Control Panel box to facilitate connection of electrical conduit for input power supply wiring, and contactor output wiring.
3. Remove the lower front access cover to begin connecting wiring. On the back of the access cover is a wiring guide label.
4. Connection to the SMMC-3 is done through terminal blocks. Fish the wire being connected through the adjacent knock-out, and pull out approximately 12+of wire. The top half of the terminal block is removable for easy wiring; gently pull up on the top half to remove. After connecting the wire to the top half gently set it back into the base while carefully pulling back excess wire through the knock-out.

Fig.3 Mounting: mounts to wall via three #10 screws

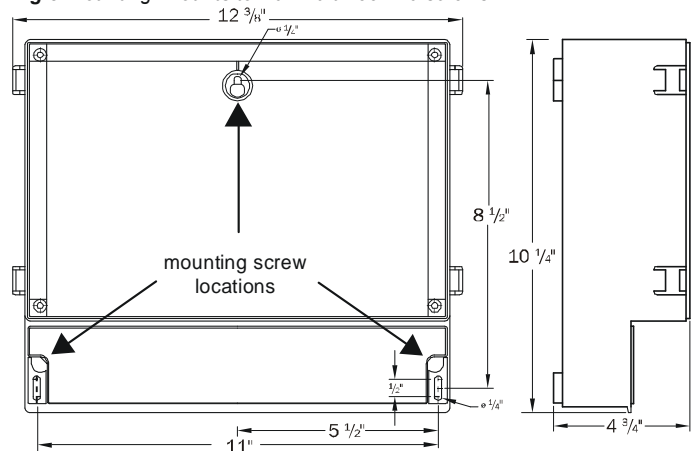

5. The SMMC-3 terminal blocks serve 5 distinct connection sectors (see *Fig 4*), they are:
 1. SMTS-1 . temperature sensor.
 2. SMAS-1 aerial sensors / SMGS-1 gutter sensors (one each per zone).
 3. SMPS-1 in-ground sensors (one each per zone).
 4. Output to power contactors (one each per zone).
 5. Control power input.

Connection to each sensor is described below:

6. The SMTS-1 is connected to the left-most terminal block, identified as **TEMP. SENSOR**. The SMMC-3 will not function if the SMTS-1 wire color codes are not properly matched at the terminal block. See *Fig. 4*
7. The SMAS-1 or the SMGS-1 may be connected to any one of the 3 terminal blocks, identified as **A/G. SENS**. The Zone number at the terminal block correlates to a snow-melting zone, ensure that the sensor is connected to the proper zone terminal. The SMMC-3 will not function properly if the SMAS-1 / SMGS-1 wire color codes are not properly matched at the terminal block. See *Fig. 4*
8. The SMPS-1 may be connected to any one of the 3 terminal blocks identified as **PAV. SENS**. The zone number at the terminal block correlates to a snow-melting zone; ensure that the sensor is connected to the proper zone terminal. The SMMC-3 will not function properly if the SMPS-1 wire color codes are not properly matched at the terminal block. See *Fig. 4*
9. The outputs to the power contactors may be connected to any one of the 3 terminal blocks in the . OUTPUT TO POWER CONTACTORS . segment, **ZONE #1, 2 OR 3**.
The Zone number at the terminal block correlates to a snow-melting zone; ensure that the output being connected matches the sensor inputs connected. The output wire must be connected with the polarity as noted, ensure voltage and amperages are suitable for the contactor being used. The SMMC-3 will not function properly if the output connections are improperly made. See *Fig. 4*
10. The power supply is connected to the right-most terminal block, identified as **POWER SUPPLY**. The power supply wires must be connected with the polarity as noted, ensure supply voltage is correct and noted ampacity is available. The SMMC-3 will not function if the power supply connections are improperly made. See *Fig. 4*
11. At this point a quick check on the power supply wiring can be made. Energize the supply circuit for the SMMC-3 Control Panel, and turn on the SMMC-3 via the toggle switch, the LCD should illuminate at this point. Reattach the front access cover; connection of the SMMC-3 is complete.
12. Each of the SMAS-1, SMGS-1 or SMPS-1 sensors connected to the SMMC-3 must be activated by programming the SMMC-3; to do so, follow the steps in the programming section of this instruction.

PRE-PROGRAMMED CONNECTIONS

1. Remove lower access panel on the SMMC-3.
2. Connect the temperature sensor lead to the temperature sensor terminal block.
3. Connect the aerial or gutter sensor lead to the Zone 1 sensor terminal block.
4. Connect the control wire from the contactor coil to the Zone 1 output terminal block, 120VAC only. **DO NOT CONNECT OUTPUT DIRECTLY TO THE LOAD. THIS WILL DAMAGE THE SMMC-3 AND CAN RESULT IN RISK OF INJURY OR FIRE.**
5. Connect 120VAC to the power supply terminal block, verify polarity.
6. Turn on the power to the SMMC-3 using the toggle switch on the front panel.
7. System is now operational.

Fig. 4 SMMC-3 Control Panel (Typical Connections)

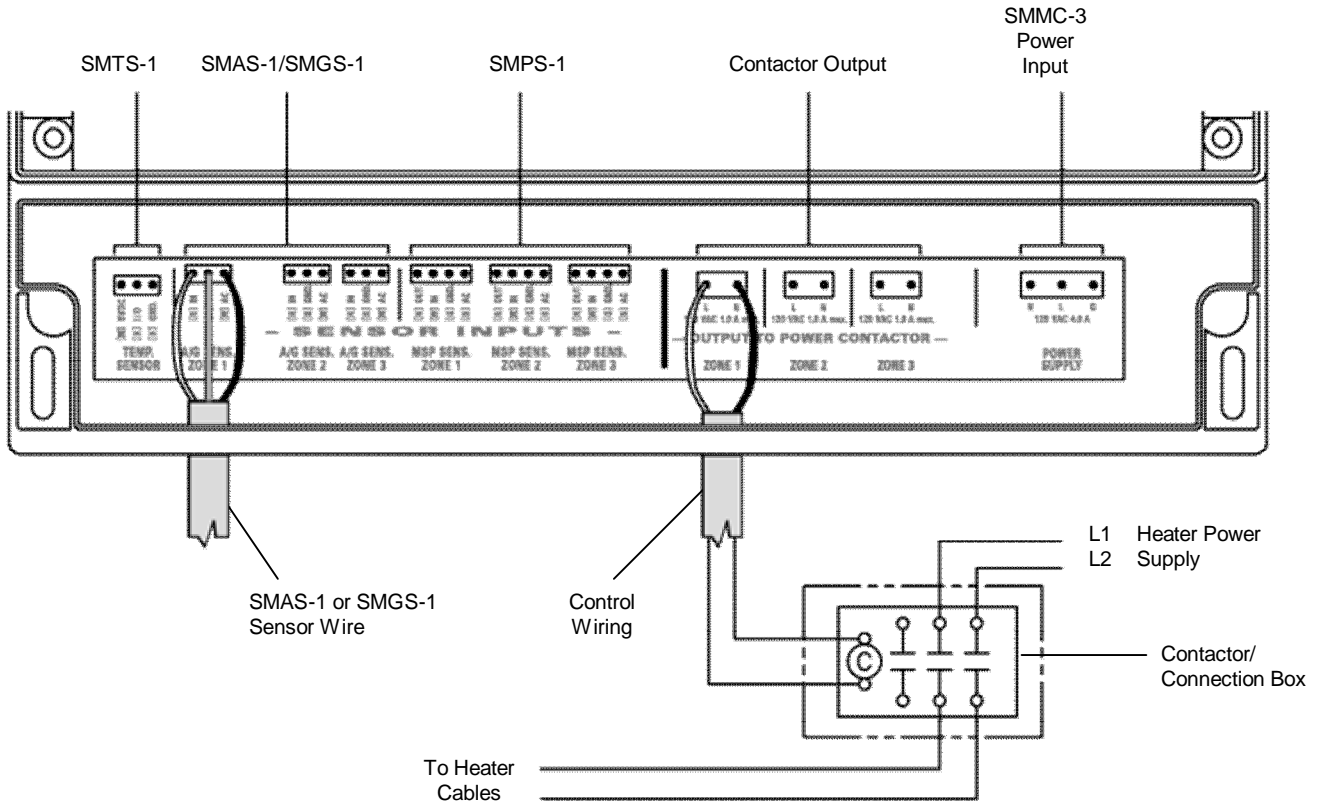

SYSTEM CHECK

Before you energize the controller, confirm:

- All the sensors, relay coils and the power supply are connected to the proper terminal blocks.
- Only approved cable was used to extend the sensors.
- The polarity of the 120 VAC power supply is appropriate.
- You have connected the output terminals to a relay or contactor coil, NOT DIRECTLY TO THE HEATER LOAD.

After energizing the controller, you should see:

- The display lit and reading the temperature in the area of the SMTS-1.
- The Small green LED next to the connected terminal blocks are lit (no LED for the SMTS-1 block).

To cycle system and check sensor operation:

1. Submerge the SMTS-1 in a quart (litre) of water and crushed ice.
2. After 20 minutes, confirm the display reads 32°F (0°C).
3. Put a drop of water on each sensor surface*, the Power Relay light(s) on the front panel will light up and the associated output relay will energize.
4. Dry off the sensor surface; the relay output will de-energize and the relay light will turn off after the pre-set hold time.

* To confirm SMPS-1 operation, the slab temperature must be below 59°F (15°C).

OPERATION

The SMMC-3 is a programmable controller, capable of controlling three separate snow/ice melting zones. A control relay for each zone is included in the SMMC-3 to operate a contactor for each zone to energize the snow/ice melting equipment. There are two operating mode selections possible with the SMMC-3:

MODE 1 – INDEPENDENT

In this mode each snow/ice melting zone is controlled independently. Mode 1 allows all 3 zones to be energized simultaneously. This mode is best used where circuit loading is not a concern (e.g. adequate circuit ampacity is available to operate the entire snow/ice melting load simultaneously).

MODE 2 – PRIORITY

In this mode each zone is controlled on a priority basis, with the most critical zone (always Zone 1) being melted first, followed then by the less critical zones. Mode 2 allows only 1 of the zones to be energized at a time. This mode is best used where circuit loading is a concern. A slight delay is provided when switching power between zones to ensure circuits are not overloaded. Set-up in Mode 2 must be done either with Zones 1 & 2, (with Zone 3 not being used), or Zones 1, 2 & 3. Operation is sequential, beginning with Zone 1. When Zone 1 is melted, the SMMC-3 de-energizes it and then energizes Zone 2. However if snow/ice is detected on Zone 1, Zone 2 is de-energized and Zone 1 re-energized. Similar logic applies for Zone 2 & 3; i.e. the lower numbered zone always takes priority.

The Priority mode available in the SMMC-3 can reduce circuit loading by splitting up a large snow melting area into separate, smaller zones. For example, if a large area would require 90 Amps of current, this could be split into two separate zones of, say, 50 Amps in one zone and 40 Amps in the other. Then, by programming the SMMC-3 in the Priority Mode, only one zone will be enabled at any one time, resulting in a maximum circuit loading of 50 Amps. Similarly, the area could be split into three zones of, say 25, 35 and 30 Amps; in this case circuit loading would be 35 Amps maximum. It should be further noted that when in Priority mode, the SMMC-3 always gives priority to Zone 1; when Zone 1 is completely melted, then Zone 2 is enabled until melted, and then, finally Zone 3; i.e. Zone 1 always has higher priority over Zone 2, which has higher priority over Zone 3. Further, if snow/ice is detected in a zone with higher priority, then operation reverts to the zone with higher priority. For example, if melting has been completed in Zone 1, and Zone 2 has been enabled, then if snow/ice is detected in Zone 1, operation in Zone 2 will be suspended, and Zone 1 will be re-enabled until melting is again complete, at which time melting in Zone 2 will recommence.

It is also important to give consideration to the assignment of zones; usually, high traffic areas will be given a high priority, with lower traffic areas given lower priority. Zones can be easily reassigned at the terminals of the SMMC-3.

ZONE ASSIGNMENT

The SMMC-3 uses the concept of a zone system to most efficiently control snow/ice melting equipment. The term **zone** means an area (either surface area or roof/gutter area, or some combination of both) heated by a specific set of snow/ice melting equipment that is controlled in a common manner. The SMMC-3 allows for up to three zones, and each zone can have multiple moisture sensors for, say, roof/gutter, aerial and/or surface snow/ice detection. If any one of the sensors detects moisture, the heating equipment may be energized. The moisture sensor in the zone should be generally, surrounded by the heating equipment to ensure that the heating equipment is only energized when there is snow/ice present in the zone. Zones can be used to represent different areas; for example a parking ramp area could be one zone while roof/gutter de-icing on the same building could be another zone. Similarly, two sidewalks on different sides of the same building (possibly one on the north side and one on the south side) could represent two separate zones. The perimeter of a football stadium could be split into three separate zones to reflect different weather conditions on different sides of the building.

MANUAL OPERATION

The power to any one of the snow-melting zones may be activated manually by pressing and holding the **ZONE X** button until the information below appears on the LCD screen. Manual activation will only work as long as the ambient temperature is below the SMMC-3 shut-off temperature. The duration of the time the zone will remain energized (Time Delay) is pre-set to 2.0 hours; this can be adjusted by following the programming instructions below. The minimum and maximum settings possible are noted on the LCD, adjustable in 0.5 hour increments.

M. Time Delay Zone 1
 min.0 <2.0H> Max.10

Pressing **UP** increases the delay time.
 Pressing **DOWN** decreases the delay time.
 Press the **SET** button to accept the chosen delay time.

Once the delay time is set, the SMMC-3 returns to normal control function, and energizes the heating equipment for the selected zone.

To de-energize the manually activated heating equipment, use the toggle switch on the front panel.

When operating in Mode 2 . Priority, the manual override works as described if no snow melting zones are energized. If any snow-melting zone is energized the manual override only works to energize the higher priority zone, thereby de-energizing the lower priority zone.

It is important to note that manual operation is not possible if the SMMC-3 has already energized the zone, and that manual control will be overridden if the zone moisture sensor detects precipitation.

LCD Explanation

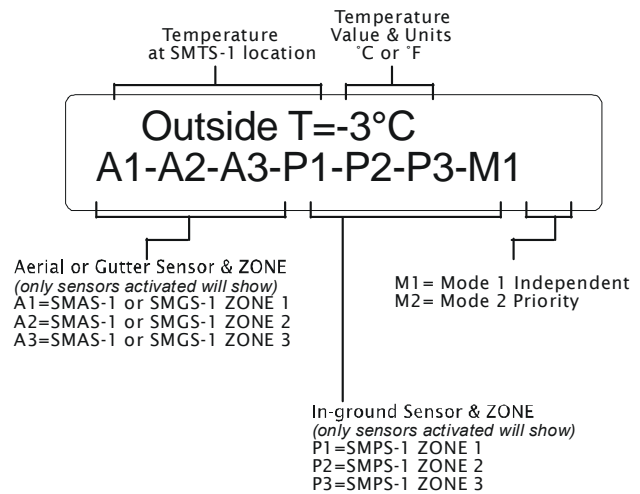

PROGRAMMING INSTRUCTIONS

The SMMC-3 program has been structured into 6 levels; within each of these levels are further degrees of selection. Each programming step is clearly described on the LCD, and easily adjusted by the “UP”, “DOWN”, and “SET” buttons.

During programming:

- All regular operating functions of the SMMC-3 are suspended.
- If a button is not pressed for approximately 90 seconds, the program will return to normal operation, saving programming changes made up to the point exited.
- Pressing the **BACK** button results in an exit from the programming sequence, with the changes made up to that point saved.

Resetting to Factory Conditions

When the SMMC-3 is first energized, and during the time the initial LCD display (SMMC Ver. X.X) screen shows push the **UP** and **DOWN** buttons simultaneously to access the option to revert to factory set conditions. Use the **UP** or **DOWN** button to select **Yes** or **No**; the program accepts the selection and returns to normal operation.

To begin programming the SMMC-3 hold the **SET** button down for 5 seconds. The display will start in program level 1. To move to other levels use the **UP** or **DOWN** buttons.

Level 1. Temperature Unit Selection

PROGRAM MODE
1. Degree: °C or °F

The default temperature units setting is °F.

To move to the next level use the **UP** or **DOWN** buttons. Press the **SET** button to select the temperature display units.

1. Degree: °C or °F
<°C > <°F >

Pressing **UP** selects Degrees C.

Pressing **DOWN** selects Degrees F.

After pressing the **UP** or **DOWN** button, the program automatically accepts the selection and advances to the next program level.

Level 2. Operating Mode Selection

PROGRAM MODE
2.Mode: 1 or 2

The default mode setting is Mode 1.

To move to the next level use the **UP** or **DOWN** buttons.

Press the **SET** button to select the operating mode.

2.Mode: 1 or 2

<No.1 > <No.2 >

Pressing **UP** selects Mode 1 (Independent).

Pressing **DOWN** selects Mode 2 (Priority).

After pressing the **UP** button for Mode 1, the program automatically accepts the selection and advances to the next program level.

After pressing the **DOWN** button for Mode 2, the program automatically accepts the selection and then moves to another input screen, as shown below.

2. Mode No.2
<2zones> <3zones>

Pressing **UP** selects a 2 Zone system (Zone 1 & 2).

Pressing **DOWN** selects a 3 Zone system (Zone 1, 2 & 3).

After pressing the **UP** or **DOWN** button, the program automatically accepts the selection and advances to the next program level.

Level 3. Sensor Activation/De-activation

PROGRAM MODE
3.Sensor Activation

The default sensor activation setting is for an aerial (SMAS-1), or gutter (SMGS-1) sensor, zone 1.

To move to the next level use the **UP** or **DOWN** buttons.

Press the **SET** button to begin the process to activate or deactivate sensors. Each of the 3 control zones may have up to 2 individual sensors, for a total of 6 sensors. <A/G.ZoneX> refers to either an SMAS-1 or SMGS-1 sensor, <P.ZoneX>, refers to an SMPS-1 in-ground sensor. The activation/deactivation operation for all 6 sensors must be stepped through before this operation is complete.

3.Sensor Activation
Yes <A/G.Zone1> No

3.Sensor Activation
Yes <A/G.Zone2> No

3.Sensor Activation
Yes <A/G.Zone3> No

3.Sensor Activation
Yes <P.Zone1> No

3.Sensor Activation
Yes <P.Zone2> No

3.Sensor Activation
Yes <P.Zone3> No

Pressing **UP** activates the selected sensor.
Pressing **DOWN** de-activates the selected sensor.
After pressing the **UP** or **DOWN** button for <P.Zone3>, the program automatically accepts the selections and advances to the next program level.

Level 4. Ambient Off Temperature Setting

PROGRAM MODE 4.Ambient Off Temp.

The default ambient off temperature is 37°F (3°C).
To move to the next level use the **UP** or **DOWN** buttons.
Press the **SET** button to adjust the ambient off temperature, the temperature above which the SMMC-3 will no longer energize the heating equipment. The minimum and maximum settings possible are noted on the LCD.

4.Ambient Off Temp.
min.34 <37°F> Max.50

Pressing **UP** increases the degree setting.
Pressing **DOWN** decreases the degree setting.
Press the **SET** button to accept the chosen ambient off temperature and advances to the next program level.

Level 5. Slab Off Temperature Setting

PROGRAM MODE 5.Slab Off Temp.

The default slab off temperature is 50°F (10°C).
To move to the next level use the **UP** or **DOWN** buttons.
Press the **SET** button to adjust the slab off temperature, the temperature above which the SMMC-3 will de-energize the in-ground heating equipment. The minimum and maximum settings possible are noted on the LCD.

5.Slab Off Temp.
min.41 <50°F> Max.68

Pressing **UP** increases the degree setting.
Pressing **DOWN** decreases the degree setting.
Press the **SET** button to accept the chosen slab off temperature and advances to the next program level.

Level 6. Setting the Relay Hold Time

PROGRAM MODE 6.Relay Hold Time

The default relay hold time is 3.0 hours for all zones.
To move to the next level use the **UP** or **DOWN** buttons.

Press the **SET** button to adjust the relay hold time for the snow melting zones. The relay hold time is the amount of time the snow melting zone remains energized after the moisture sensor is dry. Each of the 3 zones is set independently, in 0.5 hour increments. The minimum and maximum settings possible are noted on the LCD. The relay hold times for all 3 sensors must be stepped through before this operation is complete.

6.Relay Hold Time Z1
min.0 <3.0H> Max.10

6.Relay Hold Time Z2
min.0 <3.0H> Max.10

6.Relay Hold Time Z3
min.0 <3.0H> Max.10

Pressing **UP** increases the relay hold time.
Pressing **DOWN** decreases the relay hold time.
Press the **SET** button to accept the chosen relay hold time and advance to the timing for the next zone.

After the hold time for Zone 3 has been set the program automatically returns to programming Level #1 Temperature Unit Selection+. To exit the programming sequence and return to normal control operation press the **BACK** button.

Temperature Stand-by

Whenever the ambient air temperature exceeds the ambient off temp, the SMMC-3 goes into a temperature stand-by+ mode, at which time all moisture sensors are de-activated. As soon as the ambient air temperature drops below the ambient off temp, the sensors are reactivated and operation begins as normal.

Outside T = 10°F
Temperature Stand-by

Error Messages

The SMMC-3 will display an error message whenever a problem is detected with the connection to the SMTS-1 or any of the SMPS-1's. Note that the connection status to a gutter (SMGS-1) or aerial (SMAS-1) sensor is not monitored by the SMMC-3.

SMTS-1 Error

Manual only <M1>
Error!- SMTS-1 <cancel>

SMPS-1 Error

Error!- SMPS-1
 <cancel>

The error screen will flash intermittently with the standard operating screen. To cancel the error message press the **DOWN** button when the error screen is showing.

If there is a SMTS-1 error all automatic operation of the SMMC-3 ceases, however manual operation of each zone is still possible.

If there is an SMPS-1 error, automatic control of the associated zone is suspended, again manual operation is still possible. Once the sensor problem has been fixed turn off the power to the SMMC-3 Control Panel at the toggle switch, reconnect the sensor wiring to the terminal block, then after a minimum 10 seconds turn back on the power. The SMMC-3 program will recognize the sensor and begin normal operation.

TROUBLESHOOTING GUIDE

SYMPTOMS	PROBABLE CAUSE	CORRECTION
System is not operating and system light is not lit.	No Power to SMMC-3	Turn on power using switch on front panel.
Display is not lit and power switch is on.	Supply not energized or power input fuse burned out.	Check power supply. If LED above power input terminal connection is not lit, replace fuse (4A spare fuse) supplied with SMMC-3.
System is not operating, Temperature Standby on display.	The SMMC-3 is in a standby mode, the ambient temperature outside is above the programmed temperature required to melt snow.	NORMAL OPERATION
Error! . SMTS-1 on display and system not operating.	There is a communication problem with the temperature sensor	Make sure the temperature sensor lead wires are connected to the terminal properly. If the sensor wire has been extended, use 3 Conductor Instrumentation Cable, #18AWG, unshielded, common conductors such as twisted pair communications wire, telephone wire, electrical building wire and doorbell wire is not acceptable. Manufacturer: Belden #5301UE or equal.
Error! . SMTS-1 on display after corrections made.	Need to clear SMTS-1 error from SMMC-3 program.	Turn off system using the front panel switch, wait 10 seconds and turn on again. The SMMC-3 should now recognize the sensor.
Error! . SMPS-1 on display and system not operating.	There is a communication problem with the in-ground sensor.	Make sure the in-ground sensor lead wires are connected to the terminal properly. If the sensor wire has been extended, use 4 Conductor Instrumentation Cable, #18AWG, shielded, common conductors such as twisted pair communications wire, telephone wire, electrical building wire and doorbell wire is not acceptable. Manufacturer: Belden #9418 or equal.
The aerial or gutter sensors are wet (covered in snow), the LED above the corresponding terminal block is lit and the system is not heating.	Possible communication problem with the aerial or gutter sensor. No error message will show on the display when this occurs.	Make sure the in-ground sensor lead wires are connected to the terminal properly. If the sensor wire has been extended, use 3 Conductor Instrumentation Cable, #18-20AWG, shielded or unshielded, common conductors such as twisted pair communications wire, telephone wire, electrical building wire and doorbell wire is not acceptable. Manufacturer: Belden #8770 or equal.
The in-ground sensor is wet (covered in snow), the sensor surface is warm and system is not heating.	The surface of the in-ground sensor may be dirty, possibly covered with sealant.	Clean the sensor surface to get rid of any contaminant, use mild detergent and carefully scrub with steel wool.

SMMC-3 CONTROL PANEL (ACCESS COVER REMOVED)

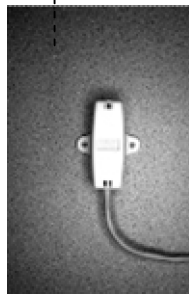
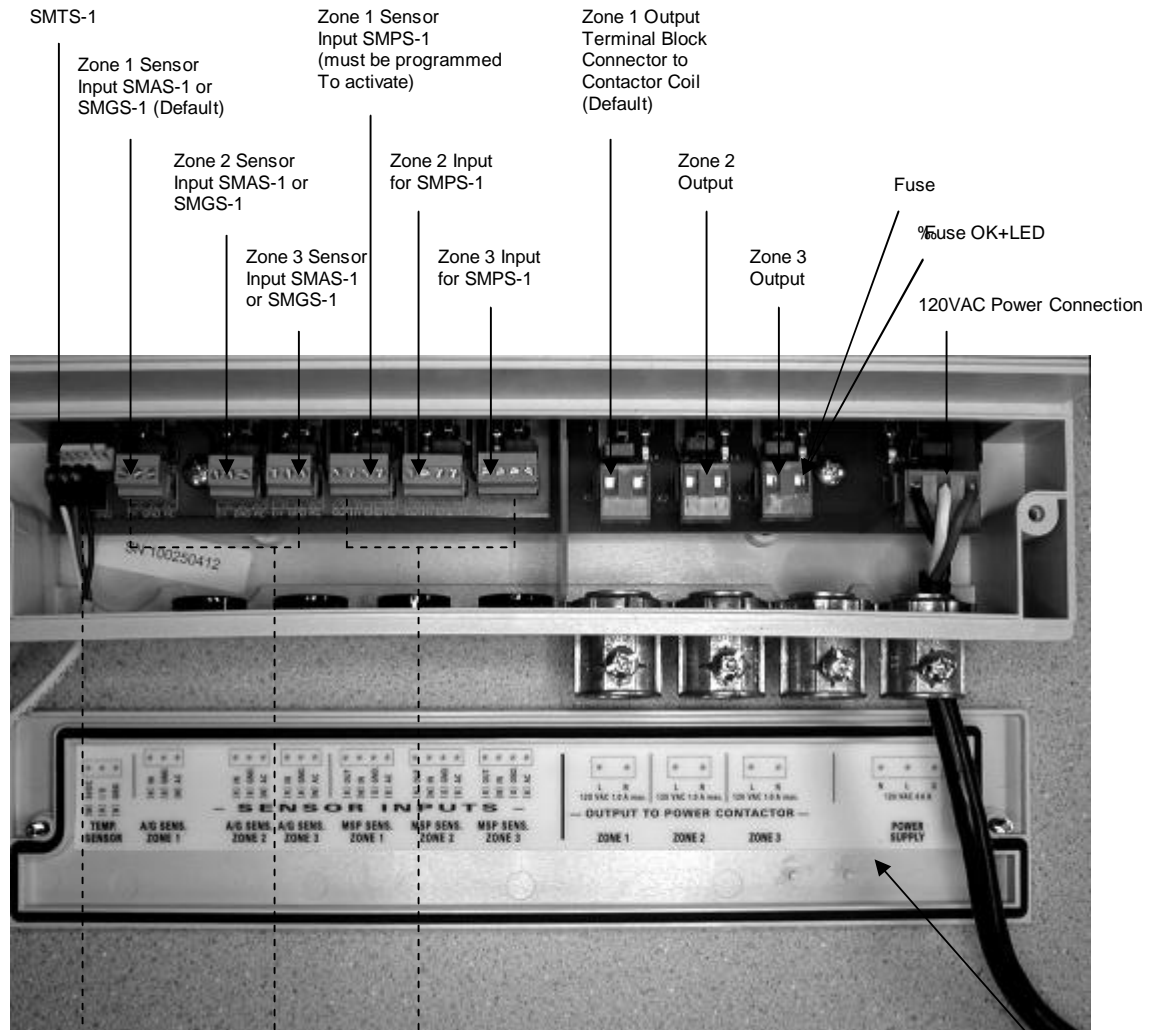

Temperature Sensor, SMTS-1: this is included with the SMMC-3 and must be installed outdoors to sense air temperature.



Aerial Snow Sensor, SMAS-1: Mast mounted to sense falling snow (may be used as the preprogrammed sensor).

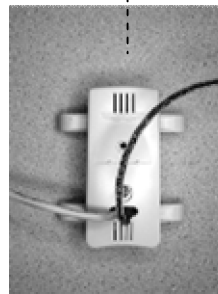

Gutter Sensor, SMGS-1: secured in the gutter to detect moisture conditions (may be used as the preprogrammed sensor).

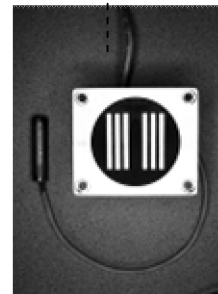

In-Ground Sensor, SMPS-1: installed in-ground to detect moisture and slab temperature (the SMMC-3 must be programmed to recognize this sensor, refer to the instruction manual for details).

SPECIFICATIONS

Electrical

Power Requirements

120 VAC, 50/60 hz, 480VA

Control Relays – Outputs

120 VAC, Pilot Duty, 120VA

Power Supply – Sensors

24 VAC, Class 3, 12VA

Temperature Sensor Supply

5 VDC, Class 2, 0.5VA

Mechanical

NEMA 12 non-metallic enclosure

System Memory

Non-Volatile: no data loss with a loss of system power

Dimensions

12.375+W x 10.25+H x 4.75+D

Certification



Environmental Specifications

Ambient Operating Temperature Range

-4°F to 160°F / -20°C to 70°C

Storage Temperature

-4°F to 185°F / -20°C to 85°C

Relative Humidity

0 to 90% RH, non condensing

SENSOR EXTENSION WIRE SPECIFICATIONS

Aerial Sensor SMAS-1

3 Conductor Instrumentation Cable, #18-20AWG, shielded or unshielded, common conductors such as twisted pair communications wire, telephone wire, electrical building wire and doorbell wire is not acceptable.

Manufacturer: Belden #8770 or equal

Gutter Sensor SMGS-1

3 Conductor Instrumentation Cable, #18-20AWG, shielded or unshielded, common conductors such as twisted pair communications wire, telephone wire, electrical building wire and doorbell wire is not acceptable.

Manufacturer: Belden #8770 or equal

Temperature Sensor SMTS-1

3 Conductor Instrumentation Cable, #18AWG, unshielded, common conductors such as twisted pair communications wire, telephone wire, electrical building wire and doorbell wire is not acceptable.

Manufacturer: Belden #5301UE or equal

Pavement Sensor SMPS-1

4 Conductor Instrumentation Cable, #18AWG, shielded, common conductors such as twisted pair communications wire, telephone wire, electrical building wire and doorbell wire is not acceptable.

Manufacturer: Belden #9418 or equal

LIMITED WARRANTY AND LIABILITY

Nelson warrants that if there are any defects in material or workmanship in any heating cable or accessory during the first year (two years on MI or self regulating heaters) after the date of its purchase, we will provide new products to replace any defective items, or we will refund the purchase price paid for the accessory or cable, not including any labor or other installation costs. As an alternate, we may elect to repair the cable or accessory at our factory with all shipping and other removal costs borne by the purchaser.

We further warrant that any services performed for the Buyer hereunder will be performed in a good and skillful manner, based on our understanding of pertinent technical data as of the date of performance of such services. Nelson's sole responsibility and liability in the event of any defect, error, omission, or failure in the services rendered hereunder shall be to provide corrected services of the type provided for herein, designed to correct such defect, error, omissions, or failure, and in no event shall the Nelson's liability with respect to such warranty exceed the amount received by it from the Buyer on account of such services.

Our obligation to provide corrected services, new products, refund the purchase price, or perform the repair described above is conditioned upon (a) the installation of the accessory or cable conforming to the specifications set forth in our installation instructions and (b) the accessory or cable not having been damaged by mechanical or electrical activities unrelated to the operation of the accessory or cable.

A refund of your purchase price, provision of replacement products the repair of the accessory or cable or provision of corrected services as described above shall be your sole and exclusive remedy for a breach of this warranty. THESE ARE THE SOLE AND EXCLUSIVE WARRANTIES GIVEN BY NELSON WITH RESPECT TO THE GOODS AND SERVICES AND ARE IN LIEU OF AND EXCLUDE ALL OTHER WARRANTIES, EXPRESS OR IMPLIED, ARISING BY OPERATION OF LAW OR OTHERWISE, INCLUDING WITHOUT LIMITATION, MERCHANTABILITY AND FITNESS FOR A PARTICULAR PURPOSE WHETHER OR NOT THE PURPOSE OR USE HAS BEEN DISCLOSED TO NELSON IN SPECIFICATIONS, DRAWINGS OR OTHERWISE, AND WHETHER OR NOT NELSON'S PRODUCTS ARE SPECIFICALLY DESIGNED AND/OR MANUFACTURED BY NELSON FOR YOUR USE OR PURPOSE.

This warranty does not extend to any losses or damages due to misuse, accident, abuse, neglect, normal wear and tear, negligence (other than Nelson's), unauthorized modification or alteration, use beyond rate capacity, or improper installation, maintenance or application. To the extent that you or your agents has supplied specifications, information, representation of operating conditions or other data to Nelson in the selection or design of the Goods and the preparation of Nelson's quotation, and in the event that actual operating conditions or other conditions differ from those represented by you, any warranties or other provisions contained herein which are affected by such conditions shall be null and void.

If within thirty (30) days after your discovery of any warranty defects within the warranty period, you notify Nelson thereof in writing, Nelson shall, at its option, repair, correct or replace F.O.B. point of manufacture, or refund the purchase price for, that portion of the Goods found by Nelson to be defective. Failure by you to give such written notice within the applicable time period shall be deemed an absolute and unconditional waiver of your claim for such defects. Goods repaired or replaced during the warranty period shall be covered by the foregoing warranty for the remainder of the original warranty period or ninety (90) days from the date of shipment, whichever is longer.

This limited warranty does not cover any costs relating to the repair or replacement of any accessory or cable at the installation site. Our accessories and cables are not easily accessible. A failed accessory or cable usually cannot be easily repaired. Replacement of a failed accessory or cable will require that the materials under which it is installed be removed to permit replacement of the accessory or cable. **We will not reimburse any costs relating to the repair or replacement of any accessory or cable at the installation site.**

IN NO EVENT, REGARDLESS OF THE FORM OF THE CLAIM OR CAUSE OF ACTION (WHETHER BASED IN CONTRACT, INFRINGEMENT, NEGLIGENCE, STRICT LIABILITY, OTHER TORT OR OTHERWISE), SHALL NELSON'S LIABILITY TO YOU AND/OR YOUR CUSTOMERS EXCEED THE PRICE PAID BY YOU FOR THE SPECIFIC GOODS PROVIDED BY NELSON GIVING RISE TO THE CLAIM OR CAUSE OF ACTION. YOU AGREE THAT WE SHALL NOT BE LIABLE TO YOU OR YOUR CUSTOMERS FOR ANY INCIDENTAL, SPECIAL OR CONSEQUENTIAL OR PUNITIVE DAMAGES. No agent, employee or representative of ours has authority to bind us to any affirmation, representation or warranty concerning the goods sold unless such affirmation, representation or warranty is specifically incorporated by written agreement.

To obtain new products, arrange repair of existing product, or a refund under this warranty, please contact Nelson with a description of the defect and proof of purchase at the addresses noted herein.